

2018-2019

Geometry Honors

Final Exam Review Packet

In addition to completing this packet in its entirety, you should review your notes and assessments from each of the units studied this semester. The units covered on this final exam include:

- Chapter 8 (Right triangles)
- Chapter 9 (Circles)
- Chapter 11 (Area of plane figures)
- Chapter 12 (Surface Area and volume of solids)
- Chapter 13 (Coordinate Geometry)
- Chapter 14 (Transformations)

Format of the Final Exam:

3	Open Ended (show all work in packet)	3 pts. each	9
41	Multiple Choice (on scantron)	1 pt. each	41
23	Fill-in/Free Response (show all work in packet)	2 pts. each	46
2	Grid-in Response (show work in packet)	2 pts each	4
		Total	100

Name: _____

1. (Chp 8) Round to the nearest hundredth.

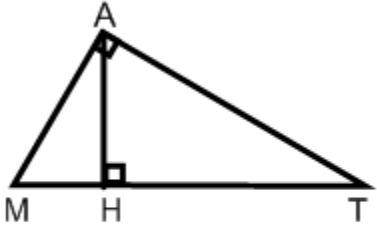

If $AM=10$ and $AT = 12$

then $MH =$ _____

$AH =$ _____

2. (Chp 9) Find the value of X.

$X =$ _____

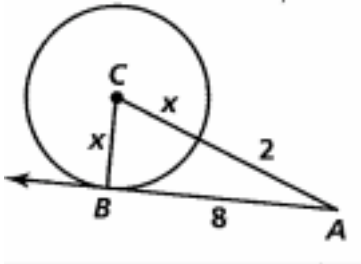

3. (Chp 12) A square pyramid has base edge 3 cm and a volume of 135 cm^3 . Find the height of the pyramid.

4. (Chp 12) The base of a prism is an isosceles triangle with side lengths 13, 13, and 10 inches. The height of the prism is 7 inches. Find the lateral area, surface (total) area, and the volume of the prism.

5. (Chp 8) Find the measures (to the nearest degree) of the acute angles of a triangle with sides of 12, 16, and 20.

6. (Chp 11) Find the area of a regular nonagon with a side of 10.

7. (Chp 8) If $\cos \angle A = .5592$ then the $\tan \angle A =$ _____.

8. (Chp 11) A regular hexagon has sides with a length of 10 inches. Give an exact answer for each of the following:

Radius _____

Perimeter _____

Apothem _____

Area _____

9. (Chp 11) What is the area of a regular pentagon with side length of 10 inches? (round to the nearest 100th).

10. (Chp 9) At seven o'clock, the hands of a clock form an angle of _____.

11. (Chp 9) Find the distance X.

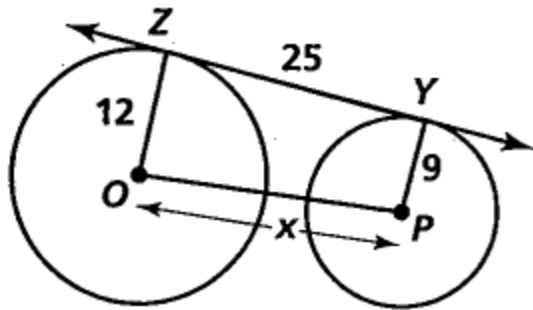

12. (Chp 9) Find the indicated measures of arcs and angles.

- $m\widehat{AE}$
- $m\angle C$
- $m\angle BEC$
- $m\angle D$

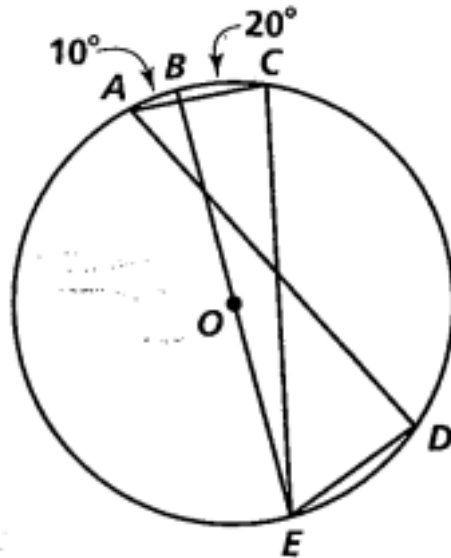

13. (Chp 12) A metal container is made of a semi-sphere and a cylinder. The diameter of the cylinder is 50cm and the height of the cylinder is 2m. Find the volume of the container.

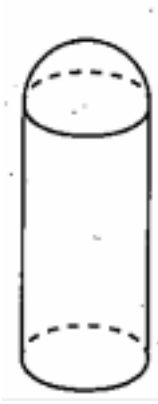

14. (Chp 13) Find the equation of a perpendicular bisector of the segments \overline{AB} where $A(-1, 5)$ and $B(3, -3)$.

15. (Chp 13) The vertices of quadrilateral OABC have coordinates $O(0,0)$, $A(5, 0)$, $B(7, 3)$ and $C(2, 3)$. Show that OABC is a parallelogram.

16. (Chp 12) Find the lateral area, volume and total area of a regular square pyramid with lateral edge 12 and slant height 10.

Lateral Area = _____

Total Area = _____

Volume = _____

17. (Chp 12) Find the total area & volume of a cylinder with height 6 ft and radius 12 ft.

18. (Chp 12) Two spheres have a scale factor of 3:4. What is the ratio of their areas? Volumes?

19. (Chp 12) Find the volume of the prism below:

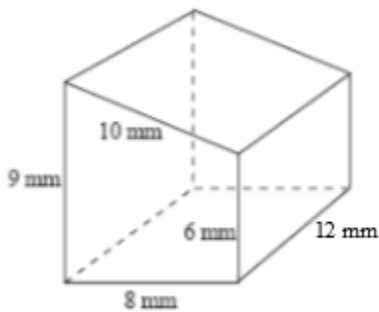

20. (Chp 13) Find the distance between and midpoint of the points (-6, 8) and (4, -5).

Distance - _____

Midpoint - _____

21. (Chp 13) Name the center and radius of the circle $(x - 3)^2 + (y + 7)^2 = 27$

Center - _____

Radius - _____

22. (Chp 13) Determine if the following lines are parallel, perpendicular or neither.

$$4x + 6y = 24$$

$$2x + 3y = -15$$

23. (Chp 14) If function $h: x \rightarrow 3x - 12$, what is the image of 6? What is the preimage of 5?

24. (Chp 14) If $T: (x, y) \rightarrow (3x - 5, 2y + 2)$, what is the preimage of $(29, 7)$?

25. (Chp 14) If $P(-4, 5)$, name P' after reflection over:

x-axis - _____

y-axis - _____

$y = x$ - _____

$y = -x$ - _____

26. (Chp 14) What is the image of $(-6, 7)$ after a transformation that moves all points 3 units up and 7 units left?

27. (Chp 14) Name 3 rotations equivalent to $\mathfrak{R}_{0,45}$.

28. (Chp 14) If O is the origin, the image of point (-6, 9) under D_0 , $D_{0, \frac{1}{3}}$ is _____

29. (Chapter 8) Given the right triangle below, find $\sin x$, $\cos x$ and $\tan x$.

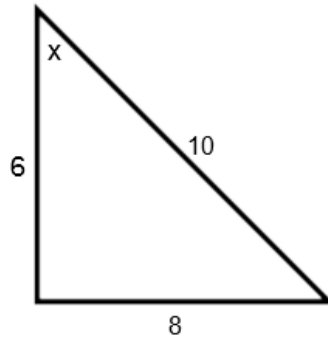

$\sin x =$ _____

$\cos x =$ _____

$\tan x =$ _____

30. (Chp 13) A triangle has vertices (-6, 2), (3, 3) and (9, -1). Determine the exact lengths of the sides of the triangle and whether the triangle is acute, right or obtuse. Simplify any radical answers.

Circle the letter of the correct answer.

31. (Chp 8) Find x and y .

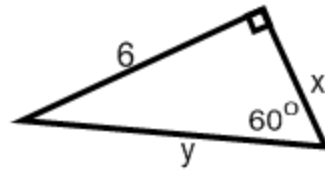

- a. $\sqrt{3}, 2\sqrt{3}$ b. $2\sqrt{3}, 2\sqrt{6}$ c. $3, 3\sqrt{3}$ d. $2\sqrt{3}, 4\sqrt{3}$

32. (Chp 8) The geometric mean of 4 and 6 is

- a. 24 b. 5 c. $2\sqrt{6}$ d. none of these

33. (Chp 8) Which of the following can be lengths of sides of a right triangle?

- a. $\sqrt{3}, \sqrt{4}, \sqrt{5}$ b. 5, 6, 7 c. $\sqrt{2x}, \sqrt{5x}, \sqrt{7x}$ d. none of these

34. (Chp 8) If $\triangle ABC$ is an isosceles right triangle and $AB = 12$, find AC .

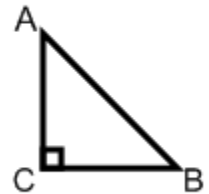

- a. 6 b. 12 c. $6\sqrt{2}$ d. none of these

35. (Chp 9) If $\angle B$ is inscribed in an arc that measures 84° , then $m\angle B$ is equal to

- a. 42 b. 84 c. 168 d. none of these

36. (Chp 9) An angle that intercepts a minor arc is

- a. acute b. right c. obtuse d. cannot determine

37. (Chp 11) The diameter of a circle measures 8 cm. The area of the circle is
- a. $8\pi \text{ cm}^2$ b. $16\pi \text{ cm}^2$ c. $64\pi \text{ cm}^2$ d. none of these
38. (Chp 11) The length of an altitude of an equilateral triangle is $8\sqrt{3}$. The area is
- a. $16\sqrt{3}$ b. 64 c. $64\sqrt{3}$ d. none of these
39. (Chp 8) Which of the following can be lengths of sides of a right triangle?
- a. 2, 3, 4 b. 5, 10, 13 c. 2, 2, 5 d. none of these
40. (Chp 8) If the leg opposite the 60° angle of a $30^\circ - 60^\circ$ right triangle is $6\sqrt{3}$ cm long, then the measure of the hypotenuse is
- a. 6 cm b. 12 cm c. $12\sqrt{3}$ cm d. none of these
41. (Chp 9) An inscribed angle measures 38° . Find the measure of the arc in which the angle is inscribed.
- a. 19° b. 38° c. 76° d. none of these
42. (Chp 11) Each side of an equilateral triangle measures 7 cm. Find the length of an apothem.
- a. 3.5 cm b. $\frac{7}{2}\sqrt{3}$ cm c. $\frac{7}{6}\sqrt{3}$ d. none of these

43. (Chp 9) Given: Circle with center O with chords \overline{AB} and \overline{CD} , and $AB > CD$. What conclusion can you draw?

- a. \overline{AB} is farther from the center than \overline{CD}
- b. \overline{AB} and \overline{CD} are equidistant from the center
- c. \overline{CD} is farther away from the center than \overline{AB}
- d. It is impossible to tell without further information
- e. None of these

44. (Chp 8) If $\sin A = .866$ and $\cos A = .500$, then

- a. $\tan A = .366$
- b. $\tan A = .433$
- c. $\tan A = 1.366$
- d. $\tan A = 1.732$
- e. none of these

45. (Chp 8) Which of the following can be the lengths of a right triangle?

- a. 6, 8, 10
- b. 5, 12, 13
- c. 9, 40, 41
- d. all of these
- e. none of these

46. (Chp 11) Find the area of the shaded region.
The radius of the circle is 4 inches.
Assume the polygon is a regular hexagon.

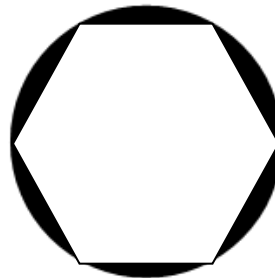

- a. $16\pi - 48\sqrt{3}$
- b. $8\pi - 24\sqrt{3}$
- c. $16\pi - 24\sqrt{3}$
- d. $8\pi - 48\sqrt{3}$
- e. none of these

47. (Chp 9) Given: $m\widehat{AD} = 50$ and $m\angle AED = 40$.

- a. $m\widehat{BC} = 10$ b. $m\widehat{BC} = 45$ c. $m\widehat{BC} = 60$
 d. $m\widehat{BC} = 90$ e. none of these

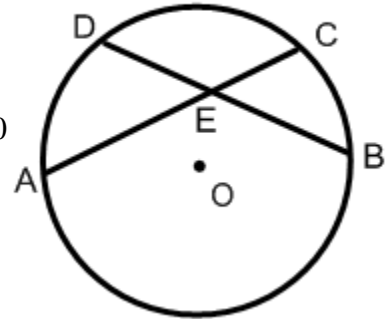

(Use diagram from #47)

48. (Chp 9) Given: $AE = 28$, $EC = 12$, and $DB = 38$.

- a. $DE = 44$ b. $DF = 16$ c. $DE = 19$ d. $DE = 24$ e. none

49. (Chp 13) The distance between the points with coordinates $(-1, 3)$ and $(2, 9)$ is

- a. $3\sqrt{5}$ b. $\sqrt{145}$ c. 45 d. 145 e. none

50. (Chp 11) The area of the given parallelogram is

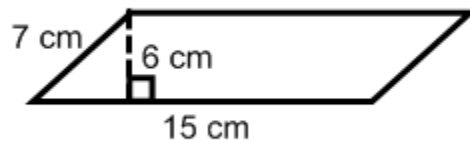

- a. 45 cm^2 b. 52.5 cm^2 c. 90 cm^2 d. 105 cm^2 e. none

More Short Answer Questions:

51. (Chp 11) Find the area of the segment in circle O.

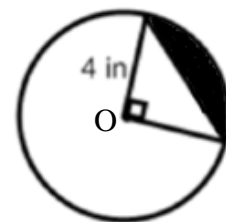

52. (Chp 8) A tree casts a 13-meter shadow when the angle of elevation of the sun is 48° . How tall is the tree?

53. (Chp 9) In a circle with center O, \overline{AB} and \overline{AE} are tangents, $\overline{BD} \parallel \overline{AE}$ and $m\widehat{ED} = 140$. Find $m\angle A$.

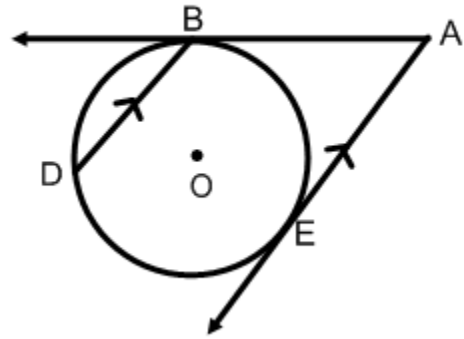

54. (Chp 8) Each side of an equilateral triangle measures 10. Find the length of an altitude in inches.

55. (Ch9) $m\widehat{AB} = 20$
 $m\widehat{CD} = 70$

$m\angle 1 = \underline{\hspace{2cm}}$

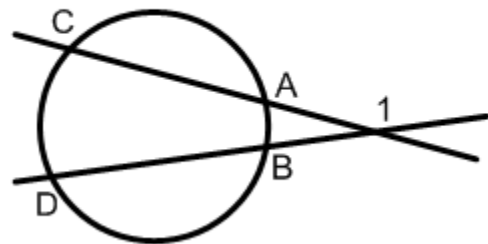

56. (Chp 8) Round to the nearest tenth:

$x = \underline{\hspace{2cm}}$

$y = \underline{\hspace{2cm}}$

$z = \underline{\hspace{2cm}}$

